



### FEATURES

- » Dual Safety Interlock system on intake nozzle & belt guard
- » Rear collection hose
- » 84 – 99 HP Diesel-powered Engine from Kubota or John Deere
- » 16" diameter discharge nozzle
- » 35-gallon fuel tank
- » 14,000-pound 3" adjustable pintle eye with safety chains
- » Standard manual or optional hydraulic jack with 3,000-pound swivel caster
- » DOT-compliant lighting and markings
- » 12-volt battery with electrical system
- » 7,000-pound axle with electric trailer brakes
- » Several feature added options available

### Titan Leaf Pro RCH

The New Titan Leaf Pro RCH vacuum collector with rear collection hose will make quick work of any cleanup job. Designed to the highest standards, the Titan Leaf Pro carries on our commitment to quality, service and customer satisfaction.

### Standard Features

The Leaf Pro sports a pull-behind design and comes attached to a 7,000-pound axle with trailer brakes. It's perfect for narrower roads and tight spaces.

*The many standard features include:*

- 16" diameter manual pickup hose and discharge nozzle
- 85 hp engine
- 35-gallon fuel tank
- Manual crank jack
- DOT-compliant lighting and markings

### Bolt-On Options

Our engineers also have designed options for the Titan Leaf Pro that are "bolt-on," making it easy and affordable to add options at any time. (See back page for a full list of options)

### Safety First

When you purchase the Titan Leaf Pro RCH vacuum collector, you can rest assured you are getting the highest in quality and safety, which have become synonymous with Titan Leaf Solutions. The Leaf Pro RCH comes with a Certificate of Origin, DOT-compliant lighting and markings, trailer brakes and dual safety interlock system. Our fabricated fluid tanks have been tested and inspected in DOT-certified facilities, and our trailers are certified by the National Association of Trailer Manufacturers (NATM). When

the nozzle is stored, the Titan Leaf Pro RCH vacuum is within the DOT's legal towing width.

When the cold winds of fall begin blowing and the colorful leaves have turned into a cleanup chore, choose the Titan Leaf Pro RCH to make quick, efficient work of your task.



Call us toll-free at **800-851-9664** for additional information and to set up your free demonstration.

# Titan Leaf Pro RCH (Rear Collection Hose)

## Specifications

Weight, Base Model	4800 LBS	Dust Control System (if equipped)	100 U.S. Gallons
Fuel Tank, Aluminum	35 U.S. Gallons	Battery	12 Volt, 1190 AMP, 950 CCA
Engine, Kubota V3600	84 HP @2600 RPM	Axle	7000 LB with Electric Brakes
Engine, Kubota V3800	99 HP @2600 RPM	Tires	ST23580R16, Load Range E
Engine, John Deere ES30159	84 HP @2400 RPM	Fan	28.5" diameter Std, 30" diameter optional
Engine, John Deere ES30161	99 HP @2400 RPM	Belts (five)	5VX

## Bolt-On Options

- 85 – 99 hp Kubota® or John Deere® engine
  - 35 - U.S. gallon fuel tank
  - 28.5" or 30" diameter fan
  - Transfluid coupler in lieu of standard clutch
  - Fixed or manual swivel discharge nozzle
  - Rear collection nozzle
  - Hydraulic or manual jack – all with swivel caster wheel
  - Directional light bar / l.e.d. flashers
  - Strobe lights
  - Camera System
  - 100-gallon dust control system
  - Fire extinguisher
  - Spare tire and wheel
  - Wheel chocks
  - Tool Rack
- (Options 8, 10, 11 & 13 not shown below)

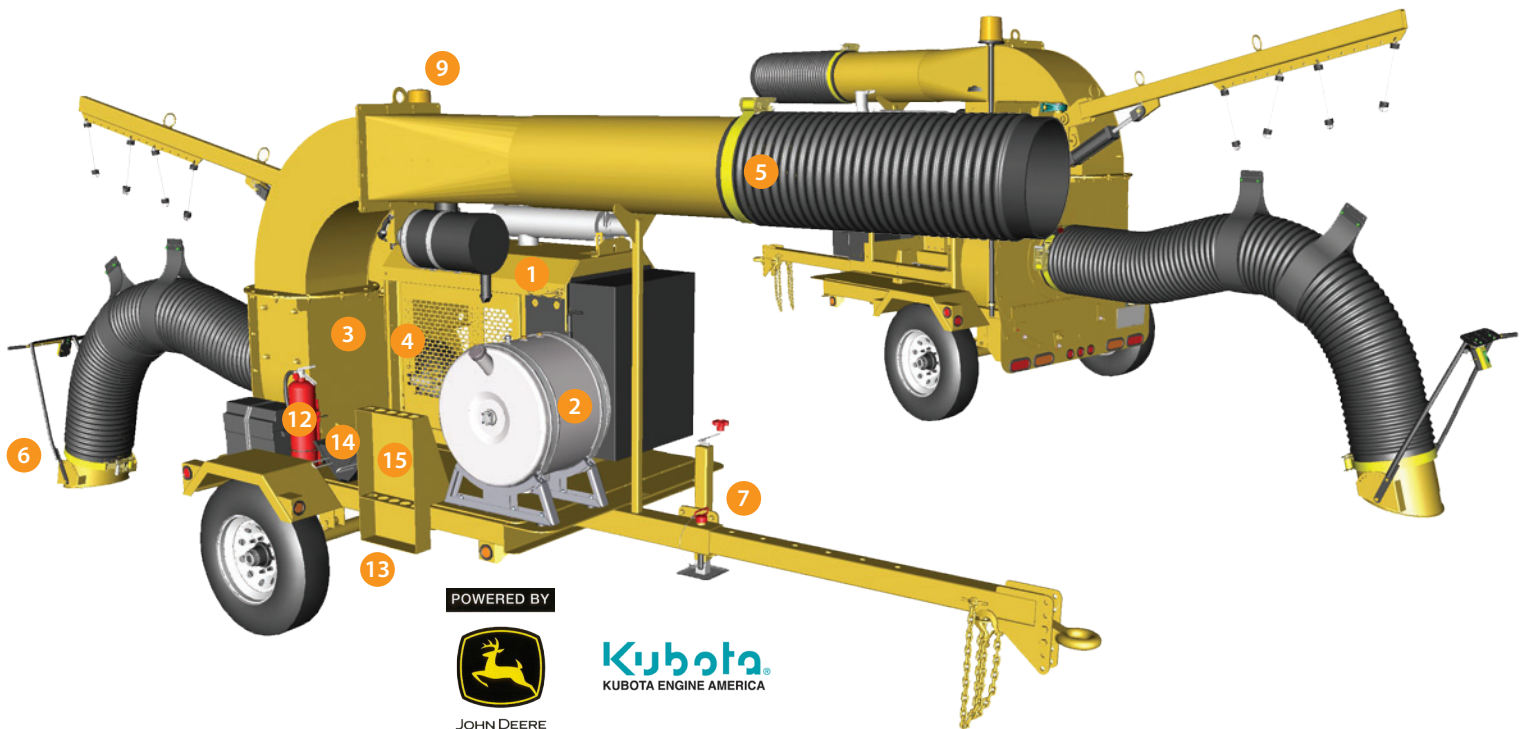

1385 Franklin Grove Rd. • Dixon, IL 61021  
 (800) 851-9664 • Fax (815) 284-8815  
[www.titanleafpro.com](http://www.titanleafpro.com)



Manufactured by Bonnell Industries, Inc. Bonnell Industries, Inc., reserves the right under its product improvement policy to change construction or design details and furnish equipment when so altered without reference to illustrations or specifications used herein.  
 © 2011 Bonnell Industries, Inc.