

### Titan Leaf Box

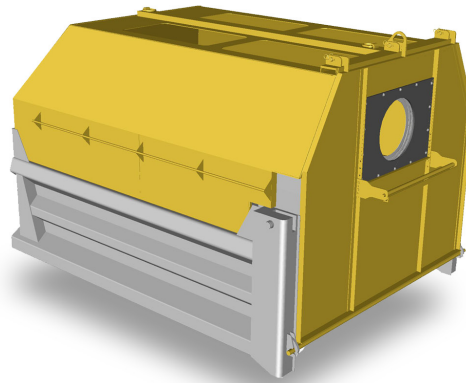

### Titan Leaf Cap

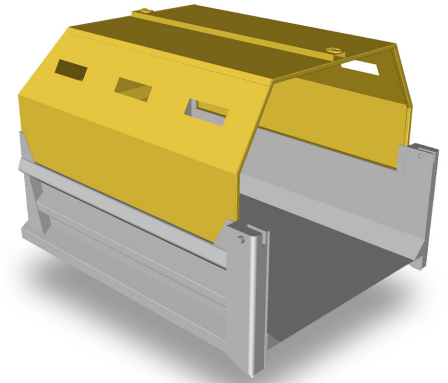

### Titan Chipper Cap

Slip in design for use in collecting leaves. Installs in a dump body or on a flat bed, and adapts to most any leaf collection unit. Many options are available to customize the Titan Leaf Box to fit your exact needs.

The ultimate in versatility, the Titan Leaf Cap combines all of the unique features of the Titan Leaf Box and Titan Chipper Cap into a single unit. Custom Fit to your existing dump body, use the Titan Leaf Cap as a leaf collection body, or remove the door and install the dump body tailgate to use as a chip collector.

Collect and haul your mulch, brush and chips in style with the Titan Chipper Cap. Each Titan Chipper Cap is custom built for an exact fit to your existing dump body. Remove the side boards, drop in place, bolt on, and go.

While leaf collection can be a drain on resources, new equipment doesn't have to bust the budget. The New Titan Leaf Box keeps that in mind, with a no frills, no nonsense design enabling you to get the job done for a reasonable price.

The Titan Leaf Box is built with what you need and no more – 12 ga. carbon steel sides and ends, 1/2" expanded metal roof, and a short floor for overhanging the floor of the host vehicle. The manual door latch is operated from the driver's side, keeping the operator out of harms way.

The 12 gauge rear door is reinforced with double crimped outer edges, and angle iron to prevent bowing. The door is hinged on three offset hinges with 1" diameter pins allowing the door to swing out and up, giving more room for large volume discharge. The door also includes a separate lifting eye for easy removal, allowing the box to be used for chip collection.

Also included is a rubber inlet hole for the vacuum nozzle. Four lifting/tie-down lugs are standard equipment as well.

The Titan Leaf Cap is premium in design and features. Combining all the features of both the Titan Leaf Box and the Titan Chipper Cap, this unit provides a sleek solution to debris containment.

The Titan Leaf Cap is constructed of 10 gauge carbon steel, with 1/2" expanded metal roof vents for leaf collection. The unit is custom fit for each application, utilizing the dump body's side board pockets for positioning and mounting.

The removable rear door is reinforced with angle iron to prevent bowing. The door is hinged on three offset hinges with 1" diameter pins allowing the door to swing out and up, giving more room for large volume discharge. The door also includes a separate lifting eye for easy removal, allowing the cap to be used for chip collection with the regular dump body tailgate. Also included is a rubber inlet hole for the vacuum nozzle.

Increase your chip debris payload with a Titan Chipper Cap! Designed to contain stray debris and chips and look good too, the Titan Chipper Cap is up to the task.

The Titan Chipper Cap is fabricated from 10 gauge carbon steel. The unit is custom fit for each application, utilizing the dump body's side board pockets for positioning and mounting.

Each side panel has vented openings, covered with expanded metal. The rear door frame is reinforced with square tubing. Lifting eyes on the top are provided for mounting and dismounting.

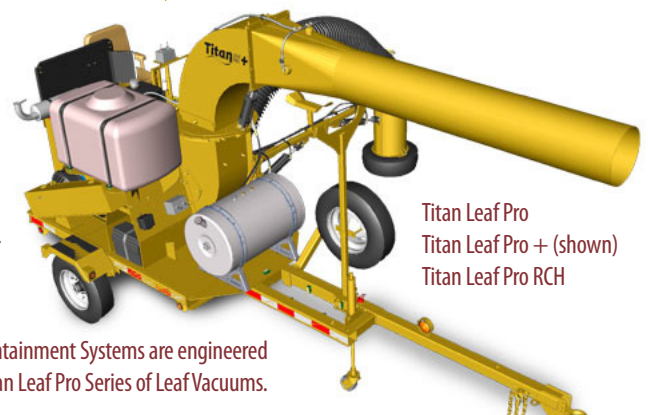

Titan Leaf Pro  
Titan Leaf Pro + (shown)  
Titan Leaf Pro RCH

Our Leaf Containment Systems are engineered to fit our Titan Leaf Pro Series of Leaf Vacuums.

Additionally, many options are available to fit your specific needs, including tarps and tarp rods, front debris deflector, support roller, tie down kits and more. See reverse side for all of the Titan Leaf Containment features!

Choose from a Yellow or Blank finish on your box, which is sandblasted, primed, sealed and then covered before paint.

For more information visit us online at [www.titanleafpro.com](http://www.titanleafpro.com)

# Titan Leaf Containment Systems

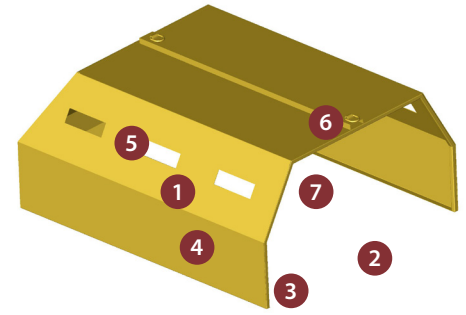
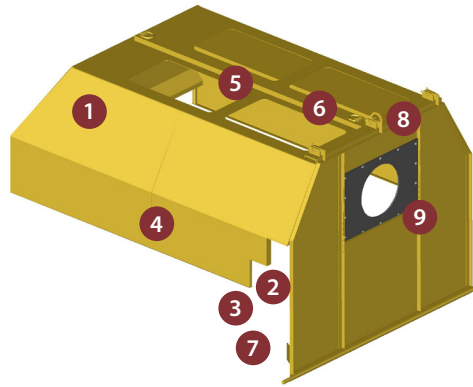
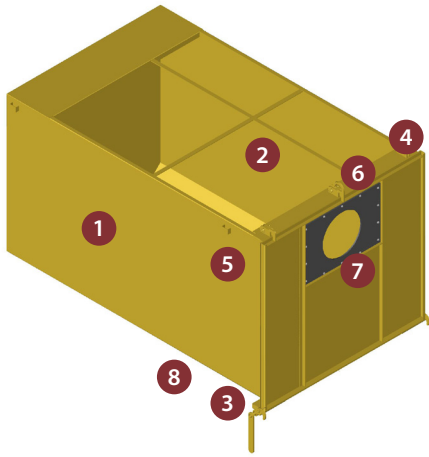

## FEATURES

1. 12-Gauge sides, front and rear door
2. 1/2" expanded metal roof
3. Manual door release, operated from drivers side
4. Door hinge: three 1" pins with offset hinges
5. Four lifting / tie down lugs
6. Separate door lifting eye
7. Rubber nozzle seal
8. Short floor design for body overhang

### LEAF BOX MODELS

Model	Length	Width	Height	Capacity (yards)
TLB8	8'	72"	72"	10
TLB9	9'	72"	72"	11.3
TLB10	10'	72"	72"	12.5
TLB12	12'	72"	72"	15

## FEATURES

1. Sloped sides and front provide styled look
2. Custom fit to your dump body
  - rubber flap supplied to help close the gap. (Note: air-tight seal not guaranteed)
3. Bolts in place using board pockets
4. 10-Gauge sides, front and door
5. 1/2" expanded metal vents
6. Top lifting eyes
7. Tubeframe around rear opening
8. Separate door lifting eye
9. Rubber nozzle seal

### LEAF CAP MODELS

Model	Length	Width	Height	Capacity (yards)
TLC8	8'	90"	46"	13
TLC10	10'	90"	46"	16
TLC12	12'	90"	46"	19

## FEATURES

1. Sloped sides and front provide styled look
2. Custom fit to your dump body
3. Bolts in place using board pockets
4. 10-Gauge sides and front
5. 3/4" expanded metal vents
6. Top lifting eyes
7. Tubeframe around rear opening

### CHIPPER CAP MODELS

Model	Length	Width	Height	Capacity (yards)
TCC8	81" +/-	90"	46"	12
TCC10	105" +/-	90"	46"	15
TCC12	129"	90"	46"	18



1385 Franklin Grove Rd. • Dixon, IL 61021  
 (800) 851-9664 • Fax (815) 284-8815  
[www.titanleafpro.com](http://www.titanleafpro.com)



Manufactured by Bonnell Industries, Inc. Bonnell Industries, Inc., reserves the right under its product improvement policy to change construction or design details and furnish equipment when so altered without reference to illustrations or specifications used herein.  
 © 2011 Bonnell Industries, Inc.